

SECTION B-B
SCALE 1 : 1

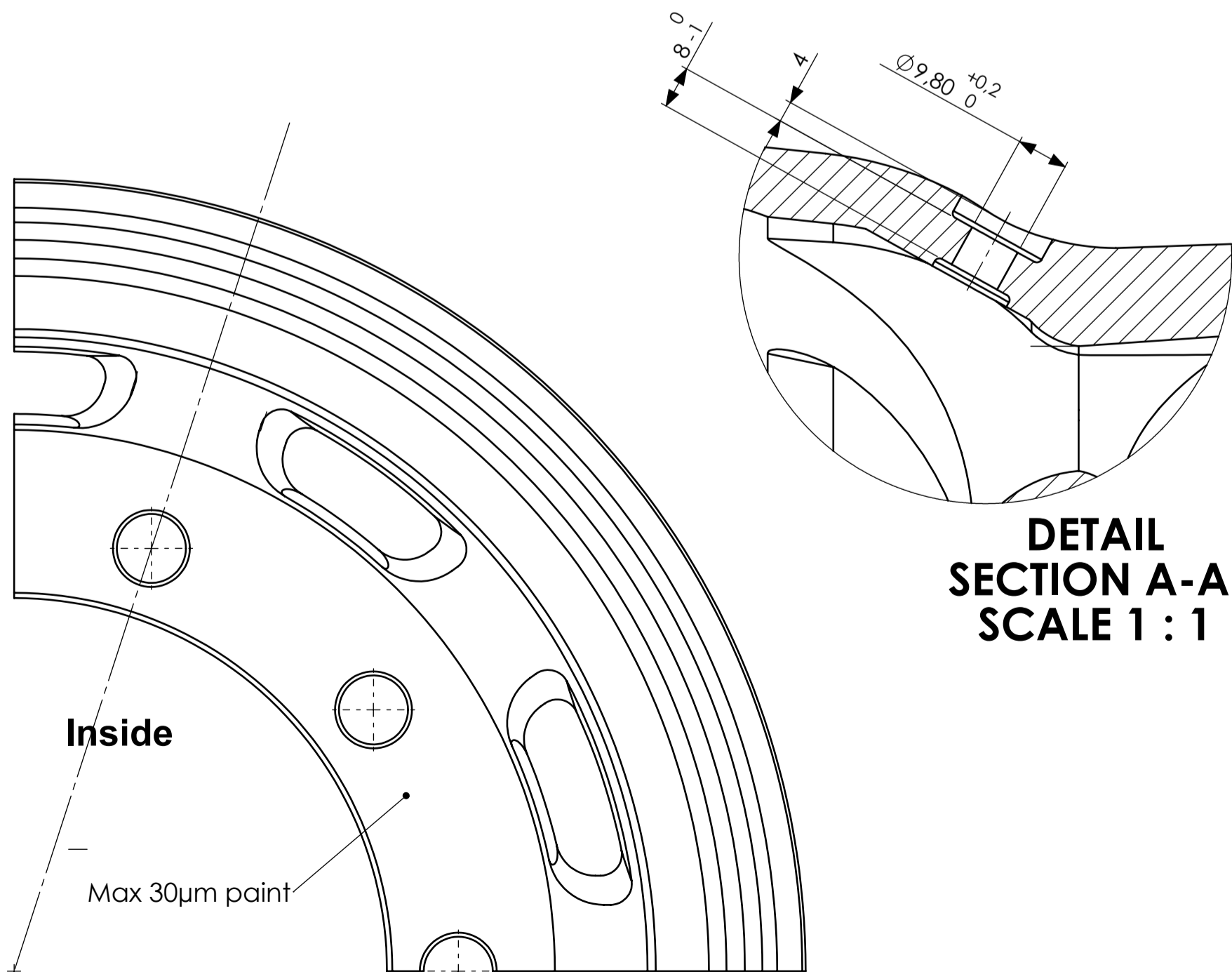

DETAIL
SECTION A-A
SCALE 1 : 1

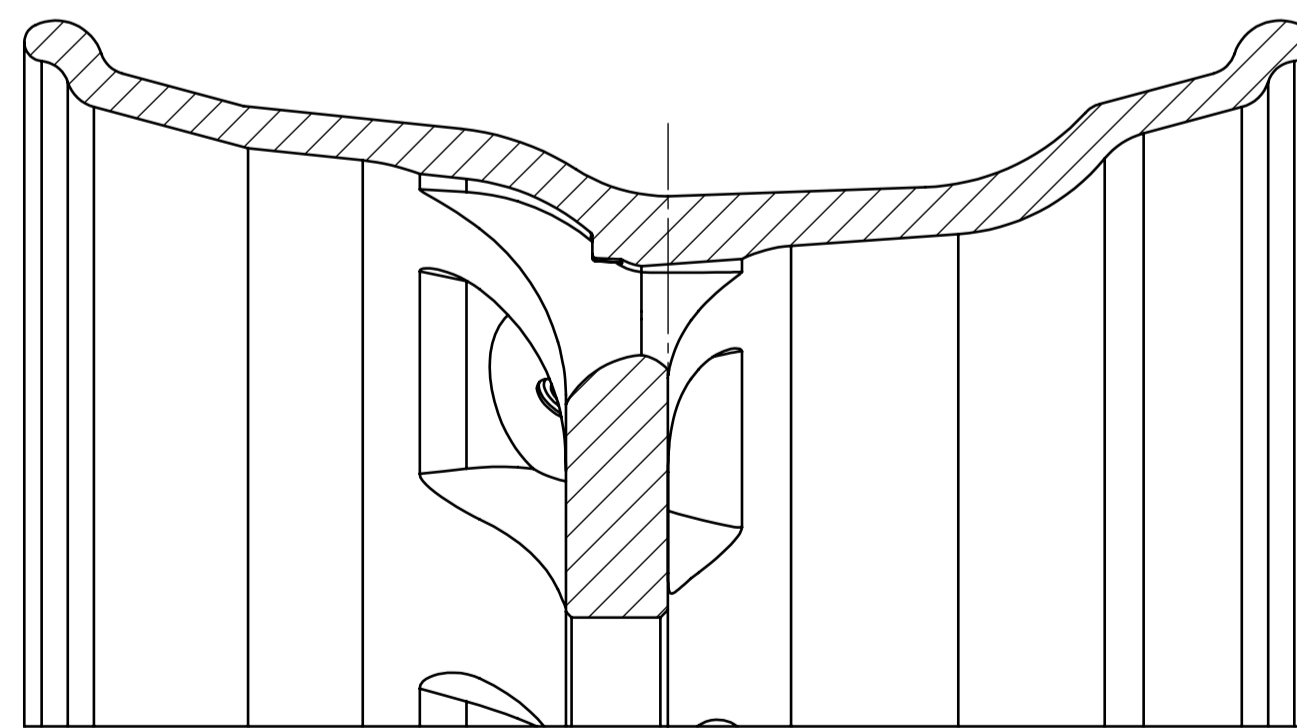

SECTION C-C
SCALE 1 : 2

STAMPED MARKINGS, by casting operator:
YEAR AND CONSECUTIVE NUMBER STARTING
FROM 0001 THE FIRST OF JAN EACH YEAR.

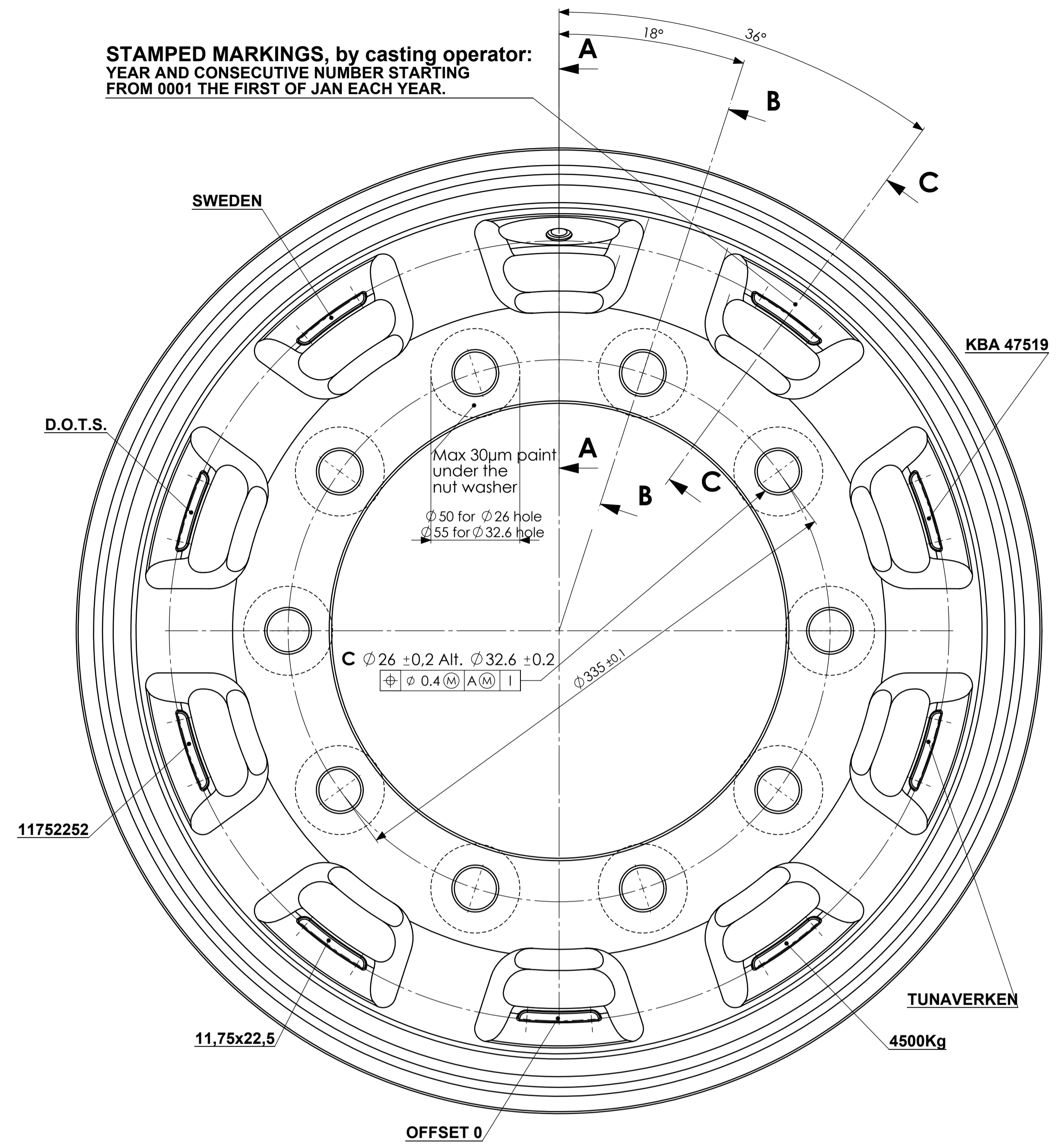

Part number	Surface	C Ø
117522521A	Crystal	26
117522521B	Crystal	32.6
117522522A	Crystal Diamond	26
117522522B	Crystal Diamond	32.6
117522523A	Black Diamond	26
117522523B	Black Diamond	32.6
117522524A	Red Diamond	26
117522524B	Red Diamond	32.6
117522525A	Diamond no clear coat	26
117522525B	Diamond no clear coat	32.6
117522526A	Polished no clear coat	26
117522526B	Polished no clear coat	32.6
117522527A	Blue Diamond	26
117522527B	Blue Diamond	32.6

Note: C Ø 32.6 is named Ø 32 everywhere else.

REMOVE BURRS
BRAKE SHARP EDGES
HARDNESS 95-110 HB
ISO 2768-C

PROPRIETARY AND CONFIDENTIAL
THE INFORMATION CONTAINED IN THIS
DRAWING IS THE SOLE PROPERTY OF
THE OWNER. ANY REPRODUCTION IN
PART OR AS A WHOLE WITHOUT THE
WRITTEN PERMISSION FROM
THE OWNER IS PROHIBITED.

Material, Weight		SS2245-07 Weight: 27kg		KBA No / Reference	
Designed by		Checked by		Date	
J.P.		Replaces drawing with same no. from 900614 and 930819		070118	
Owner		Title/Name		Drawing number	
TUNAVERKEN SWEDEN AB		Cast Wheel 11,75" x 22,5" OFFSET 0		11752252_C	
				Issue	
				03	
				A1	